

3GPP-(Technical Speciation  
Group Radio Access Network;  
Evolved Universal Terrestrial  
Radio Access (E-UTRA);  
LTE/WLAN Radio Level Integration  
Using IPsec Tunnel (LWIP)  
encapsulation; Protocol  
specification)



본 문서에 대한 저작권은 TTA에 있으며, TTA와 사전 협의 없이 이 문서의 전체 또는 일부를 상업적 목적으로 복제 또는 배포해서는 안 됩니다.

Copyright 20xx, Telecommunications Technology Association.  
All rights reserved.

# 3GPP TS 36.361 V15.0.0 (2018-07)

---

*Technical Specification*

**3<sup>rd</sup> Generation Partnership Project;  
Technical Specification Group Radio Access Network;  
Evolved Universal Terrestrial Radio Access (E-UTRA);  
LTE/WLAN Radio Level Integration Using IPsec Tunnel (LWIP)  
encapsulation;  
Protocol specification  
(Release 15)**



Keywords

---

LTE, radio

**3GPP**

Postal address

---

3GPP support office address

---

650 Route des Lucioles - Sophia Antipolis  
Valbonne - FRANCE  
Tel.: +33 4 92 94 42 00 Fax: +33 4 93 65 47 16

Internet

---

<http://www.3gpp.org>

---

**Copyright Notification**

---

No part may be reproduced except as authorized by written permission.  
The copyright and the foregoing restriction extend to reproduction in all media.

© 2018, 3GPP Organizational Partners (ARIB, ATIS, CCSA, ETSI, TSDSI, TTA, TTC).  
All rights reserved.

UMTS™ is a Trade Mark of ETSI registered for the benefit of its members  
3GPP™ is a Trade Mark of ETSI registered for the benefit of its Members and of the 3GPP Organizational Partners  
LTE™ is a Trade Mark of ETSI registered for the benefit of its Members and of the 3GPP Organizational Partners  
GSM® and the GSM logo are registered and owned by the GSM Association

---

# Contents

Foreword .....	4
1 Scope .....	5
2 References .....	5
3 Definitions, symbols and abbreviations .....	5
3.1 Definitions .....	5
3.2 Abbreviations .....	5
4 General .....	6
4.1 Introduction .....	6
4.2 LWIPEP architecture .....	6
4.2.1 LWIPEP entities .....	6
4.3 Services .....	7
4.3.1 Services provided to upper layers .....	7
4.3.2 Services expected from lower layers .....	7
4.4 Functions .....	7
5 Procedures .....	8
5.1 Data transfer procedures .....	8
5.1.1 UL data transfer procedures .....	8
5.1.2 DL data transfer procedures .....	8
5.2 Handling of unknown, unforeseen and erroneous protocol data .....	8
6 Protocol data units, formats and parameters .....	8
6.1 Protocol data units .....	8
6.1.1 General .....	8
6.1.2 LWIPEP data PDU .....	8
6.2 Formats and parameters .....	9
6.2.1 LWIPEP header .....	9
<b>Annex A (informative): Change history .....</b>	<b>10</b>

---

## Foreword

This Technical Specification has been produced by the 3<sup>rd</sup> Generation Partnership Project (3GPP).

The contents of the present document are subject to continuing work within the TSG and may change following formal TSG approval. Should the TSG modify the contents of the present document, it will be re-released by the TSG with an identifying change of release date and an increase in version number as follows:

Version x.y.z

where:

- x the first digit:
  - 1 presented to TSG for information;
  - 2 presented to TSG for approval;
  - 3 or greater indicates TSG approved document under change control.
- y the second digit is incremented for all changes of substance, i.e. technical enhancements, corrections, updates, etc.
- z the third digit is incremented when editorial only changes have been incorporated in the document.

---

# 1 Scope

The present document specifies the LWIP Encapsulation Protocol.

---

# 2 References

The following documents contain provisions which, through reference in this text, constitute provisions of the present document.

- References are either specific (identified by date of publication, edition number, version number, etc.) or non-specific.
- For a specific reference, subsequent revisions do not apply.
- For a non-specific reference, the latest version applies. In the case of a reference to a 3GPP document (including a GSM document), a non-specific reference implicitly refers to the latest version of that document *in the same Release as the present document*.

- [1] 3GPP TR 21.905: "Vocabulary for 3GPP Specifications".
  - [2] 3GPP TS 36.300: "E-UTRA and E-UTRAN Overall Description; Stage 2".
  - [3] 3GPP TS 36.331: "E-UTRA RRC Protocol specification".
  - [4] IETF RFC 2784: "Generic Routing Encapsulation (GRE)".
  - [5] IETF RFC 2890: "Key and Sequence Number Extensions to GRE".
- 

# 3 Definitions, symbols and abbreviations

## 3.1 Definitions

For the purposes of the present document, the terms and definitions given in TR 21.905 [1] and the following apply. A term defined in the present document takes precedence over the definition of the same term, if any, in TR 21.905 [1].

## 3.2 Abbreviations

For the purposes of the present document, the following abbreviations apply:

DL	DownLink
DRB	Data Radio Bearer
eNB	E-UTRAN Node B
E-UTRA	Evolved UMTS Terrestrial Radio Access
E-UTRAN	Evolved UMTS Terrestrial Radio Access Network
IP	Internet Protocol
LWIP	LTE/WLAN Radio Level Integration Using IPsec Tunnel
LWIPEP	LWIP Encapsulation Protocol
GRE	Generic Routing and Encapsulation
PDCP	Packet Data Convergence Protocol
PDU	Protocol Data Unit
RRC	Radio Resource Control
SAP	Service Access Point
SDU	Service Data Unit
UE	User Equipment

---

## 4 General

### 4.1 Introduction

The objective is to describe the use of encapsulation for IP packets over the LWIP Tunnel as defined in TS 36.300 [2] and TS 36.331 [3].

### 4.2 LWIPEP architecture

#### 4.2.1 LWIPEP entities

The description in this sub clause is a model and does not specify or restrict implementations.

RRC is in control of the LWIPEP configuration.

Functions of the LWIPEP sublayer are performed by LWIPEP entities. For an LWIPEP entity configured at the eNB, there is a peer LWIPEP entity configured at the UE and vice versa. The LWIPEP entity responsible for encapsulating LWIPEP SDUs is referred to as the transmitter. The LWIPEP entity responsible for decapsulating LWIPEP PDUs is referred to as the receiver.

An LWIPEP entity receives/delivers LWIPEP SDUs from/to upper layers (i.e. IP) and sends/receives LWIPEP PDUs to/from its peer LWIPEP entity via an LWIP Tunnel and E-UTRA.

- At the transmitting side, when an LWIPEP entity receives an LWIPEP SDU from upper layers, it constructs the corresponding LWIPEP PDU and delivers it to lower layers;
- At the receiving side, when an LWIPEP entity receives an LWIPEP PDU from lower layers, it reassembles the corresponding LWIPEP SDU and delivers it to upper layers.

Figure 4.2.1-1 illustrates the overview model of the LWIPEP sublayer.

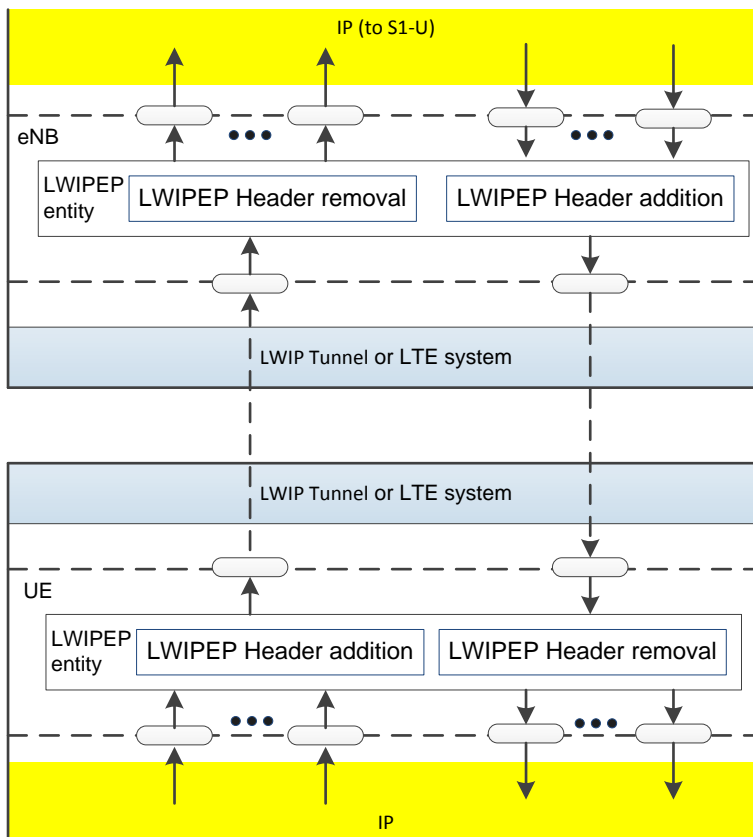

**Figure 4.2.1-1: Overview model of the LWIPEP sublayer**

An LWIPEP entity delivers/receives the following LWIPEP PDU to/from a lower layer entity:

- LWIPEP data PDU.

### 4.3 Services

#### 4.3.1 Services provided to upper layers

The following services are provided by LWIPEP to upper layers (i.e. IP):

- transfer of user plane data;

#### 4.3.2 Services expected from lower layers

The following services are expected by LWIPEP from lower layers (i.e. LWIP Tunnel and E-UTRA):

- transfer of user plane data;

### 4.4 Functions

The following functions are supported by the LWIPEP sublayer:

- transfer of user plane data;
- identification of the DRB identity to which the LWIPEP SDU belongs.



---

## 5 Procedures

### 5.1 Data transfer procedures

#### 5.1.1 UL data transfer procedures

When receiving an LWIPEP SDU from upper layers, the LWIPEP entity shall form the LWIPEP PDU as described in Section 6.1.

#### 5.1.2 DL data transfer procedures

When receiving an LWIPEP PDU from lower layers, the LWIPEP entity shall:

- if configured by upper layers to enable aggregation in DL:
  - interpret the LWIPEP PDU as having both *Key* and *Sequence Number* fields included as described in Section 6.1;
  - reorder received packets according to the *Sequence Number* field before delivering them to higher layers as specified in RFC 2890 [5];
- else:
  - interpret the LWIPEP PDU as having *Key* field included as described in Section 6.1;

### 5.2 Handling of unknown, unforeseen and erroneous protocol data

When an LWIPEP entity receives an LWIPEP PDU that contains reserved or invalid values, the LWIPEP entity shall:

- discard the received PDU.

---

## 6 Protocol data units, formats and parameters

### 6.1 Protocol data units

#### 6.1.1 General

An LWIPEP PDU is a bit string that is byte aligned (i.e. multiple of 8 bits) in length. In the figures in subclause 6.1, bit strings are represented by tables in which the most significant bit is the leftmost bit of the first line of the table, the least significant bit is the rightmost bit on the last line of the table, and more generally the bit string is to be read from left to right and then in the reading order of the lines. The bit order of each parameter field within an LWIPEP PDU is represented with the first and most significant bit in the leftmost bit and the last and least significant bit in the rightmost bit.

An LWIPEP SDU is a bit string that is byte aligned (i.e. multiple of 8 bits) in length. An LWIPEP SDU is included into an LWIPEP PDU from the first bit onward.

Only one type of LWIPEP PDU is defined, i.e. LWIPEP data PDU.

#### 6.1.2 LWIPEP data PDU

An LWIPEP data PDU consists of the LWIPEP header and the LWIPEP SDU, as described in Figure 6.1.2-1. The LWIPEP header is populated as described in 6.2.1.

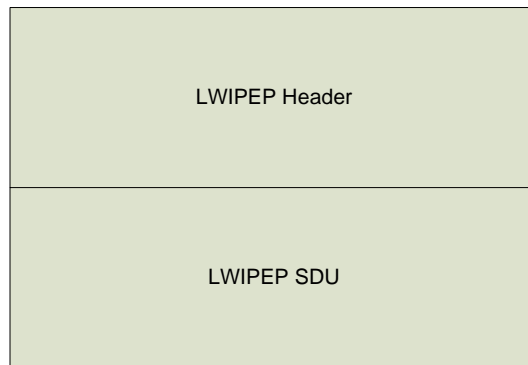

**Figure 6.1.2-1: LWIPEP data PDU**

## 6.2 Formats and parameters

### 6.2.1 LWIPEP header

The LWIPEP Header is a GRE header as specified in RFC 2890 [5] and has a fixed size of eight bytes (if only the *Key* field is included) or twelve bytes (if both the *Key* and *Sequence Number* fields are included).

The transmitter shall set the 5 LSB's of the *Key* field in the GRE header to the DRB Identity associated with the LWIPEP SDU and set the remaining MSB's to '0'. If instructed by RRC to enable aggregation in UL or DL, the transmitter shall in addition include the *Sequence Number* field as specified by RFC 2890 [5] in the LWIPEP header. All other optional fields are unused, and the values of other fields shall be set as specified in RFC 2784 [4] and RFC 2890 [5].

## Annex A (informative): Change history

Change history							
Date	TSG #	TSG Doc.	CR	Rev	Cat	Subject/Comment	New
02-2016	RAN#71	RP-160238	-	-		TS 00.001 v1.0.0 on LTE/WLAN Radio Level Integration Using IPsec Tunnel (LWIP) encapsulation; Protocol specification - This new spec is based on RAN2 agreed Tdoc <a href="#">R2-161974</a> in RAN2#93 - spec number 00.001 will be changed properly after RAN#71 approval	1.0.0
03-2016	RAN#71	RP-160607	-	-		Spec number added	1.0.1
03-2016	RAN#71	RP-160607	-	-		Approved at TSG RAN#71 and put under Change Control	13.0.0
06-2016	RP-72	RP-161080	0001	1		Corrections to LWIPEP specification	13.1.0
09-2016	RP-73	RP-161757	0002	1		Clarification on LWIPEP	13.2.0
	RP-73	RP-161757	0003	-		Correction on GRE header size	13.2.0
12-2016	RP-74	RP-162327	0004	1		Modifications to LWIPEP due to LWIP aggregation	14.0.0
03-2017	RP-76	RP-171225	0006	-	F	Clarification on LWIP aggregation	14.1.0
07-2018						Upgraded to Rel-15. No technical change.	15.0.0